

Description

The DFS450HF17I4C1 is a Half Bridge SiC MOSFET Power Module. It integrates high performance SiC MOSFET chips designed for the applications such as Motor drives and Renewable energy.



Features

- Blocking voltage 1700V
- $R_{DS(on)} = 4.3m\Omega @ T_j = 25^\circ C$
- Low thermal resistance with Si₃N₄ AMB
- Low Inductive Design
- Thermistor inside

Applications

- xEV Applications
- Motor Drives
- Servo Drives
- Smart-Grid/Grid-Tied Distributed Generation

Circuit diagram

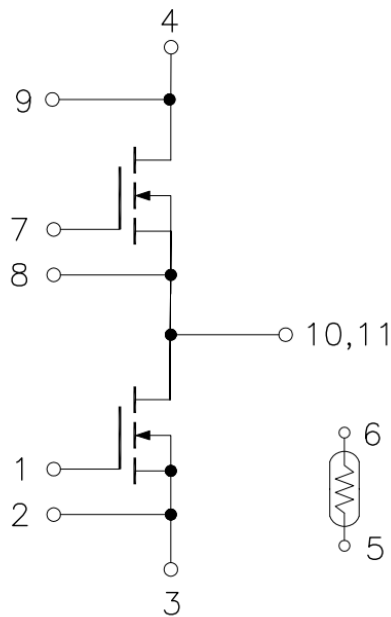

Figure 1. Out drawing & circuit diagram for DFS450HF17I4C1

Module

Parameter	Conditions	Value	Unit
Isolation Voltage	RMS, f =50Hz, t =1min	4.0	KV
Material of module baseplate	-	Cu	-
Creepage distance	terminal to heatsink terminal to terminal	14.5 10	mm
Clearance	terminal to heatsink terminal to terminal	12.5 10	mm
CTI	-	600	-
Module lead resistance, terminals–chip	T _C =25°C	0.5	mΩ
Mounting torque for module mounting	M5, M6	3 to 6	Nm
Weight	-	385	g

Maximum Ratings (T_j =25°C unless otherwise specified)

Symbol	Parameter	Conditions	Ratings	Unit
V _{DSS}	Drain-Source Voltage	G-S Short	1700	V
V _{GSS}	Gate-Source Voltage (+)	D-S Short	20	V
V _{GSS}	Gate-Source Voltage (-)	D-S Short	-10	V
V _{GSSSurge}	G-S Voltage(t _{surge} <300nsec)	D-S Short, Note1	-10 to 20	V
I _{DS}	DC Continuous Drain Current	T _C =25°C, V _{GS} =15V	505	A
I _{DS}	DC Continuous Drain Current	T _C =60°C, V _{GS} =15V	445	A
I _{SD}	Source (Body diode) Current	T _C =25°C, with ON signal	505	A
I _{SD}	Source (Body diode) Current	T _C =60°C, with ON signal	445	A
I _{DSM}	Pulse Forward Current	T _C =25°C, Pulse width =1ms, V _{GS} =15V, Note2	1000	A
P _{tot}	Total Power Dissipation	T _C =25°C	2500	W
T _{jmax}	Max Junction Temperature	-	-55 to 175	°C
T _{stg}	Storage Temperature	-	-55 to 125	°C

Note1: Recommended Operating Value, +15V/-5V, +15V/-4V

Note2: Pulse width limited by maximum junction temperature

NTC characteristics

Symbol	Parameter	Condition	Value			Unit
			Min.	Typ.	Max.	
R ₂₅	Resistance	T _C =25°C	-	5	-	kΩ
ΔR/R	Deviation of R ₁₀₀	T _C =100°C, R ₁₀₀ =493Ω	-5	-	5	%
P ₂₅	Power dissipation	T _C =25°C	-	-	20	mW
B _{25/50}	B-value	R ₂ =R ₂₅ exp [B _{25/50} (1/T ₂ - 1/(298,15 K))]	-	3375	-	K
B _{25/80}	B-value	R ₂ =R ₂₅ exp [B _{25/80} (1/T ₂ - 1/(298,15 K))]	-	3411	-	K
B _{25/100}	B-value	R ₂ =R ₂₅ exp [B _{25/100} (1/T ₂ - 1/(298,15 K))]	-	3433	-	K

MOSFET Electrical characteristics (T_j=25°C unless otherwise specified, chip)

Symbol	Item	Condition		Value			Unit	
				Min.	Typ.	Max		
V _{(BR)DSS}	Drain-Source Breakdown Voltage	V _{GS} =0V, I _D =500μA		1700	-	-	V	
I _{DSS}	Zero gate voltage drain Current	V _{DS} =1700V, V _{GS} =0V		-	-	1	mA	
I _{GSS}	Gate-Source Leakage Current	V _{GS} =15V, V _{DS} =0V		-	-	500	nA	
		V _{GS} =-10V, V _{DS} =0V		-	-	-500	nA	
V _{GS(th)}	Gate-source threshold Voltage	I _D =300mA V _{DS} =V _{GS}	T _j =25°C	1.80	2.70	-	V	
			T _j =175°C	-	1.90	-	V	
R _{DS(on)} (Chip)	Static drain-source	I _D =450A V _{GS} =15V	T _j =25°C	-	4.3	-	mΩ	
	On-state resistance		T _j =175°C	-	9.7	-	mΩ	
V _{DS(on)} (Chip)	Static drain-source	I _D =450A V _{GS} =15V	T _j =25°C	-	1.94	-	V	
	On-state Voltage		T _j =175°C	-	4.37	-	V	
C _{iss}	Input Capacitance	V _D =1000V, V _{GS} =0V		-	38.1	-	nF	
C _{oss}	Output Capacitance	f =1MHz, V _{ac} =25mV		-	1.03	-	nF	
C _{rss}	Reverse transfer Capacitance			-	0.18	-	nF	
Q _g	Total gate charge	V _{DS} =1000V		-	1280	-	nC	
Q _{gd}	Gate-Drain Charge	I _D =375A		-	450	-	nC	
Q _{gs}	Gate-Source Charge	V _{GS} =+15/-5V		-	385	-	nC	
R _{Gint}	Internal Gate Resistance	T _j =25°C		-	0.96	-	Ω	
t _{d(on)}	Turn-on delay time			T _j =25°C	-	147	-	ns
				T _j =150°C	-	119	-	
t _r	Rise time	V _{DD} =900V		T _j =25°C	-	108	-	ns
				T _j =150°C	-	89	-	
t _{d(off)}	Turn-off delay time	I _D =450A V _{GS} =+15/-5V		T _j =25°C	-	519	-	ns
				T _j =150°C	-	608	-	
t _f	Fall time	R _{G(on)} =5.1Ω R _{G(off)} =5.1Ω		T _j =25°C	-	91	-	ns
				T _j =150°C	-	107	-	
E _{on}	Turn-on power dissipation	Inductive load switching operation		T _j =25°C	-	45.5	-	mJ
				T _j =150°C	-	42.4	-	
E _{off}	Turn-off power dissipation			T _j =25°C	-	50.1	-	mJ
				T _j =150°C	-	55.3	-	
R _{th(j-c)}	FET Thermal Resistance	Junction to Case		-	0.060	-	K/W	
R _{th(c-f)}	Contact thermal Resistance	With thermal conductive grease, Note1		-	0.015	-	K/W	

Note1: Assumes Thermal Conductivity of grease is 0.9W/m·K and thickness is 50um.

Body Diode Electrical characteristics ($T_j=25^\circ\text{C}$ unless otherwise specified, chip)

Symbol	Item	Condition	Value			Unit	
			Min.	Typ.	Max.		
V_{SD}	Body Diode Forward Voltage	$V_{GS} = -5\text{V}$ $I_{SD} = 450\text{A}$	$T_j = 25^\circ\text{C}$	-	5.3	-	V
			$T_j = 175^\circ\text{C}$	-	5.0	-	
T_{rr}	Reverse recovery time	$V_{RR} = 900\text{V}, I_D = 450\text{A}$ MOSFET side:	$T_j = 25^\circ\text{C}$	-	35	-	ns
			$T_j = 150^\circ\text{C}$	-	122	-	
Q_{rr}	Reverse recovery charge	$V_{GS} = +15/-5\text{V}$ $R_{G(on)} = R_{G(off)} = 5.1\Omega$	$T_j = 25^\circ\text{C}$	-	2.34	-	μC
			$T_j = 150^\circ\text{C}$	-	12.78	-	
E_{rr}	Diode switching power dissipation	Inductive load switching operation	$T_j = 25^\circ\text{C}$	-	0.85	-	mJ
			$T_j = 150^\circ\text{C}$	-	7.0	-	

Test Conditions

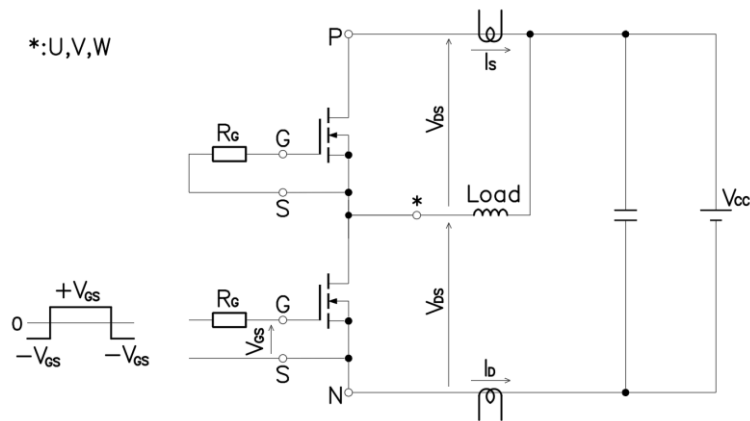

Figure 3. Switching time measure circuit

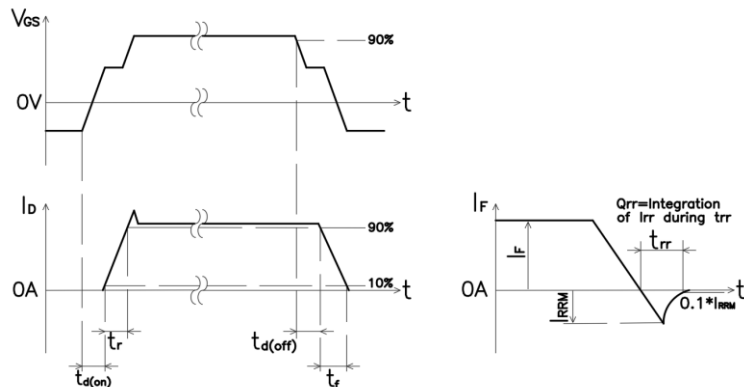

Figure 4. Switching time definition

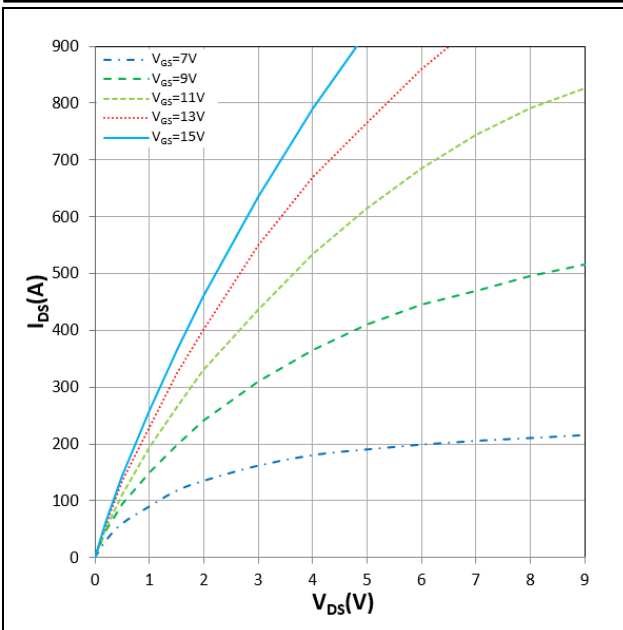

Figure 5. I_{DS} vs V_{DS}
 $T_j = 25^\circ\text{C}$, V_{GS} parameter

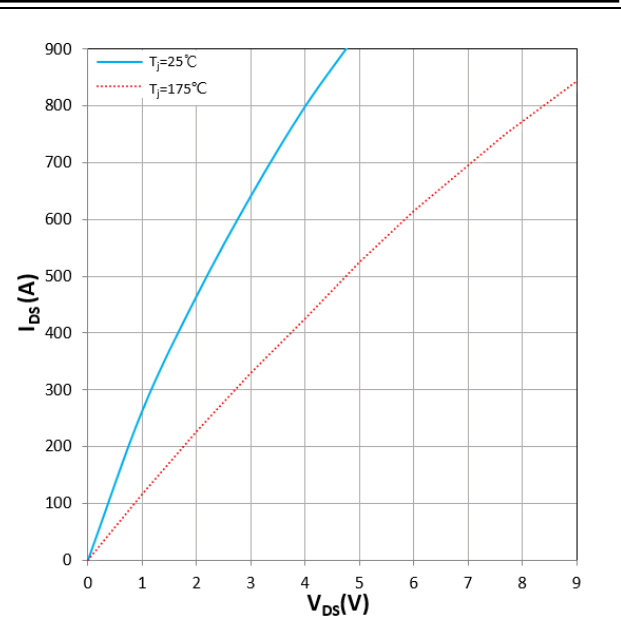

Figure 6. I_{DS} vs V_{DS}
 $V_{GS} = 15\text{V}$, T_j parameter

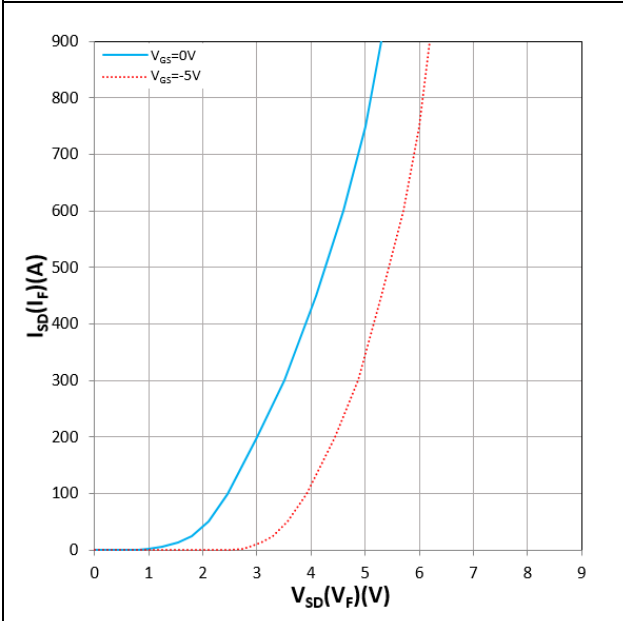

Figure 7. $I_{SD}(I_F)$ vs $V_{SD}(V_F)$
 $T_j = 25^\circ\text{C}$, V_{GS} parameter

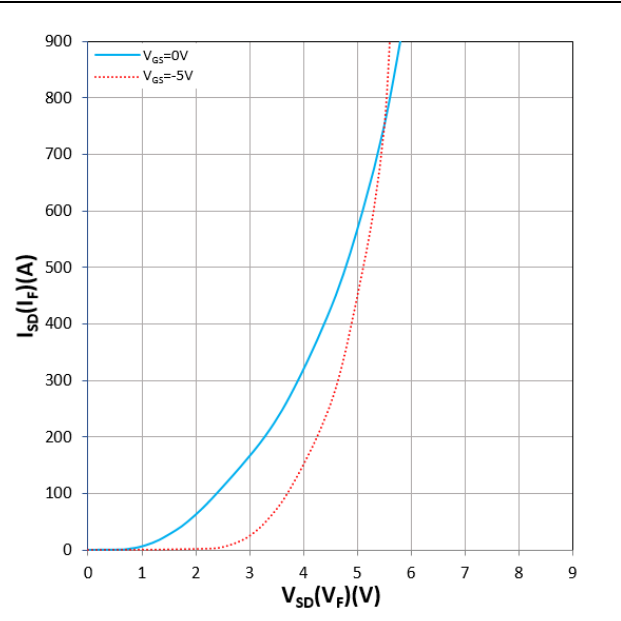
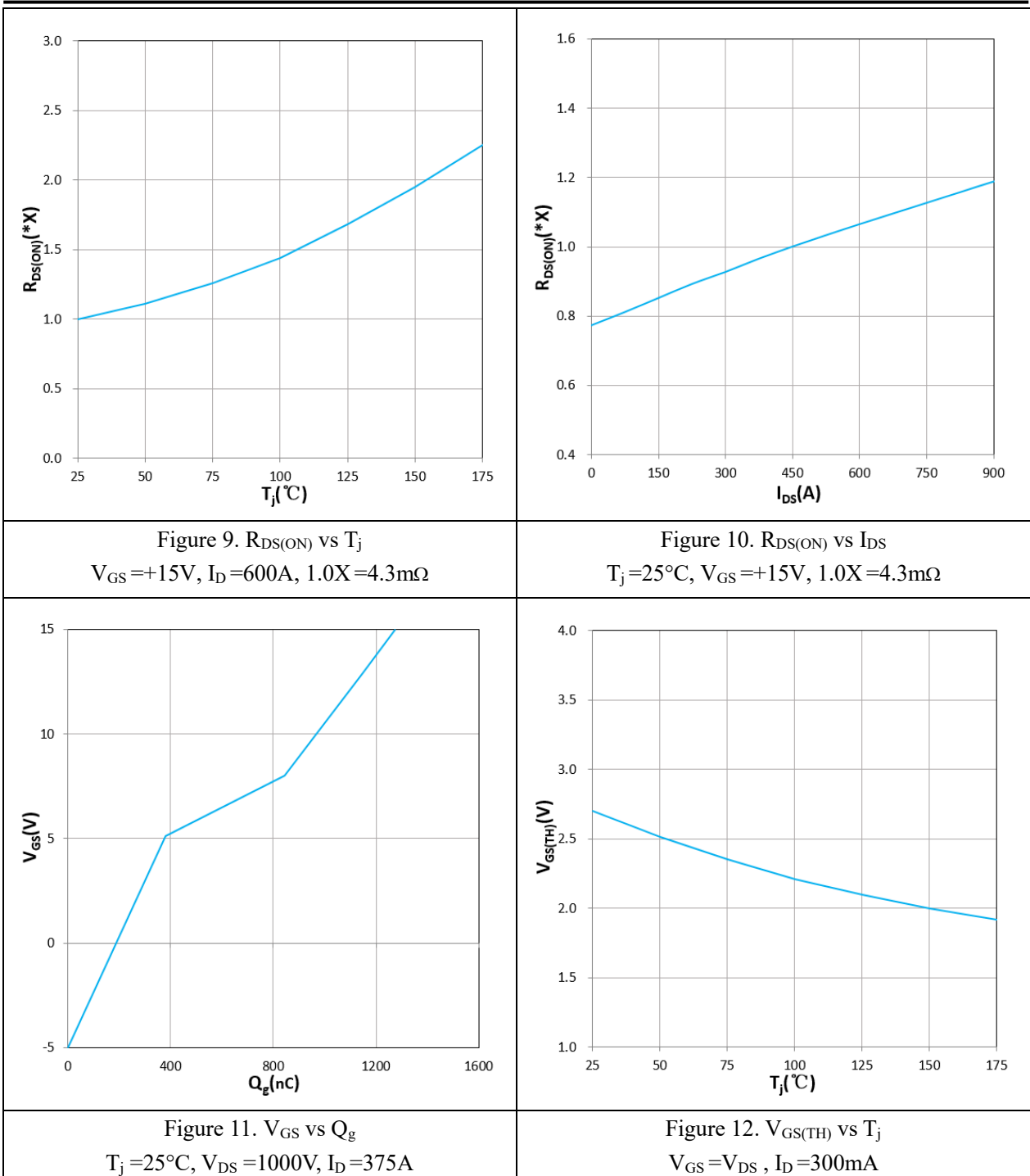

Figure 8. $I_{SD}(I_F)$ vs $V_{SD}(V_F)$
 $T_j = 175^\circ\text{C}$, V_{GS} parameter



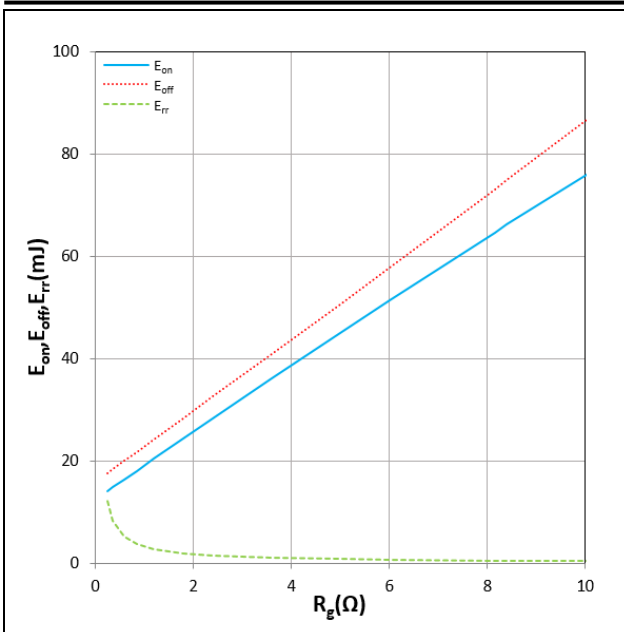

Figure 13. E_{on} , E_{off} , E_{rr} vs R_g
 $T_j=25^\circ\text{C}$, $V_{DD}=900\text{V}$, $V_{GS}=+15\text{V}/-5\text{V}$, $I_D=450\text{A}$
 Inductive Load

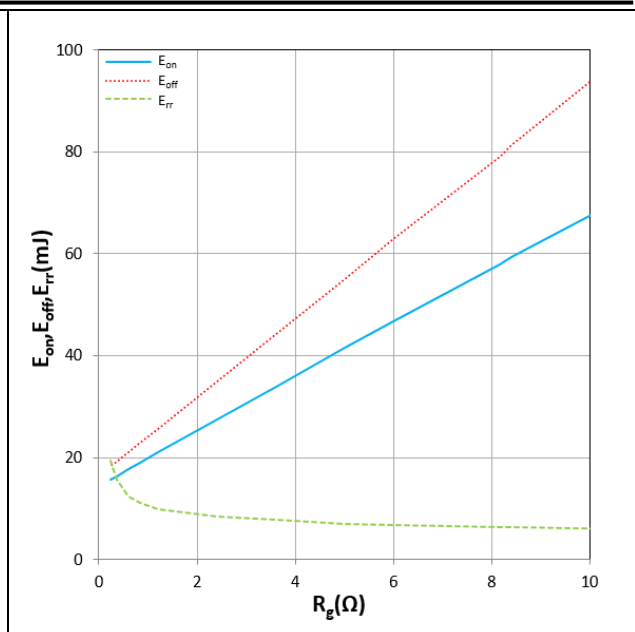

Figure 14. E_{on} , E_{off} , E_{rr} vs R_g
 $T_j=150^\circ\text{C}$, $V_{DD}=900\text{V}$, $V_{GS}=+15\text{V}/-5\text{V}$, $I_D=450\text{A}$
 Inductive Load

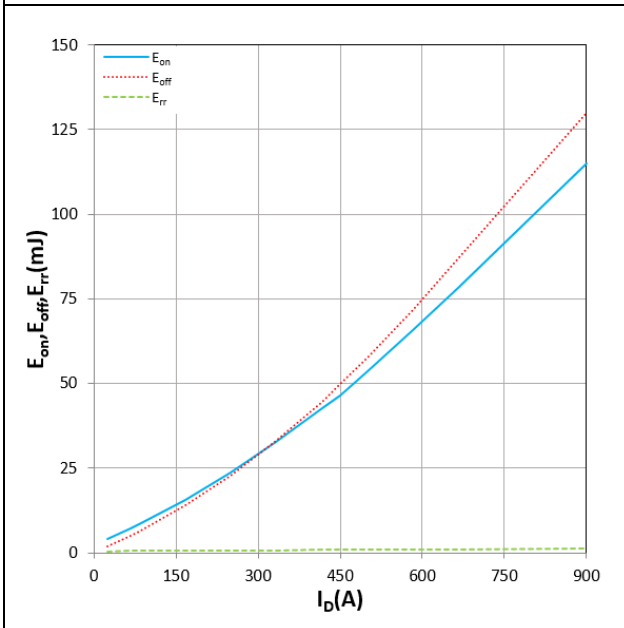

Figure 15. E_{on} , E_{off} , E_{rr} vs I_D
 $T_j=25^\circ\text{C}$, $V_{DD}=900\text{V}$, $V_{GS}=+15\text{V}/-5\text{V}$, $R_g=5.1\Omega$
 Inductive Load

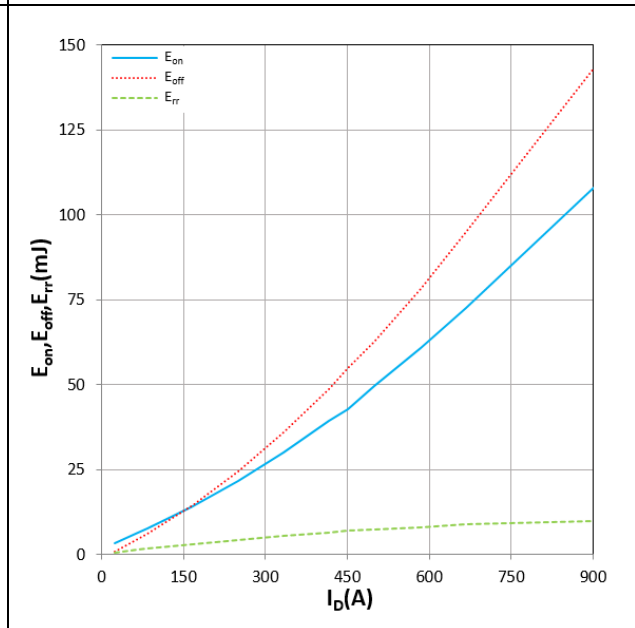

Figure 16. E_{on} , E_{off} , E_{rr} vs I_D
 $T_j=150^\circ\text{C}$, $V_{DD}=900\text{V}$, $V_{GS}=+15\text{V}/-5\text{V}$, $R_g=5.1\Omega$
 Inductive Load

IMPORTANT NOTICE:

This product data sheet describes the characteristics of this product for which a warranty is granted. Any such warranty is granted exclusively under the terms and conditions of the supply agreement. There will be no guarantee or of any kind for the product and its characteristics.

The data contained in this document is exclusively intended for technically trained staff. You and your technical departments will have to evaluate the product's suitability for the intended application and the completeness of the product data concerning such application.

Due to technical requirements, our product may contain dangerous substances. For information on the types in question, please contact the sales staff responsible for you.

Changes to this product data sheet are reserved.

Please contact the sales staff (Sales@leapers-power.com) for further information on the product, technology, delivery terms, conditions and prices.