

Description

The DFI600HF12DFH1 is a Half Bridge IGBT Power Module. It integrates high performance IGBT chips and offers lower losses and higher energy for the applications such as motor drive, inverter and welding machines.



Features

- 1200V600A
- $V_{CE(sat)}(typ.) = 1.60V$
- Lower losses and higher energy
- High speed switching

Applications

- Motor drive
- Inverter
- Welding machines
- Power supply
- UPS

Circuit diagram

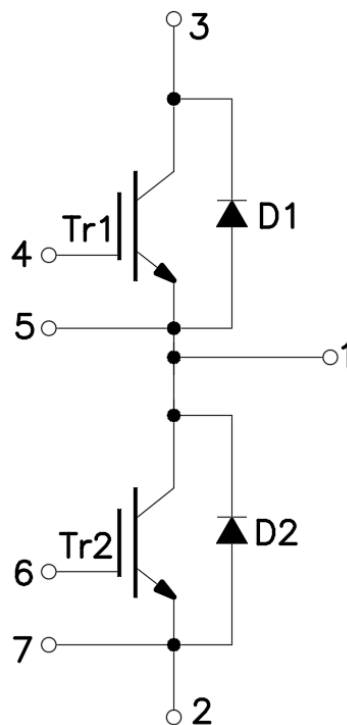

Figure 1. Out drawing & circuit diagram for DFI600HF12DFH1

Pin Configuration and Marking Information

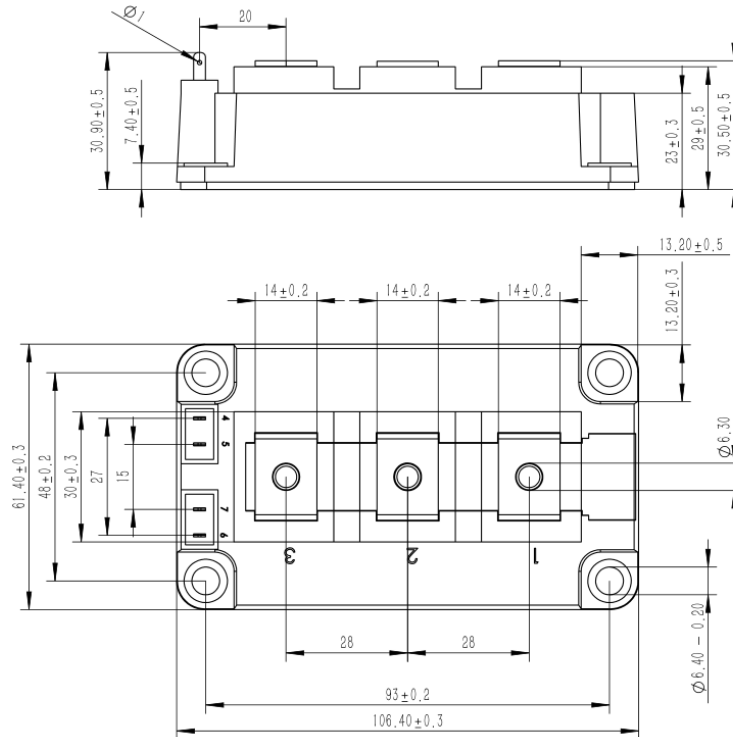

Figure 2. Pin configuration

Module

Parameter	Condition	Value	Unit
Isolation Voltage	RMS, f = 50Hz, t = 1 min	3.4	kV
Material of module baseplate	-	Cu	-
Creepage distance	terminal to heatsink	47	mm
	terminal to terminal	26	
Clearance	terminal to heatsink	29	mm
	terminal to terminal	14	
CTI	-	>200	-
Module lead resistance, terminals – chip	T _C = 25°C	0.8	mΩ
Mounting torque for module mounting	M6	3 to 6	Nm
Weight	-	315	g

Maximum Ratings (T_j = 25°C unless otherwise specified)

Symbol	Parameter	Conditions	Ratings	Unit
V _{CES}	Collector-Emitter Voltage	G-E Short	1200	V
V _{GES}	Gate-Emitter Voltage	C-E Short	±20	V
I _C	DC Continuous Collector Current	T _C = 100°C	600	A
I _{CM}	Pulse Collector Current	t _p = 1ms, Note1	1200	A
P _C	Maximum Power Dissipation	T _C = 25°C, IGBT	3333	W
I _F	Diode Forward Current	-	600	A
I _{FRM}	Repetitive peak forward Current	t _p = 1ms, Note1	1200	A
T _{jmax}	junction temperature	-	-40 to 175	°C
T _{vjop}	Operating junction temperature	-	-40 to 150	°C
T _{stg}	Storage temperature	-	-40 to 125	°C

Note1: Pulse width limited by maximum junction temperature

NTC characteristics

Symbol	Parameter	Condition	Value			Unit
			Min.	Typ.	Max.	
R ₂₅	Resistance	T _C = 25°C	-	5	-	kΩ
ΔR/R	Deviation of R ₁₀₀	T _C = 100°C, R ₁₀₀ = 493Ω	-5	-	5	%
P ₂₅	Power dissipation	T _C = 25°C	-	-	20	mW
B _{25/50}	B-value	R ₂ = R ₂₅ exp [B _{25/50} (1/T ₂ - 1/(298,15 K))]	-	3375	-	K
B _{25/80}	B-value	R ₂ = R ₂₅ exp [B _{25/80} (1/T ₂ - 1/(298,15 K))]	-	3411	-	K
B _{25/100}	B-value	R ₂ = R ₂₅ exp [B _{25/100} (1/T ₂ - 1/(298,15 K))]	-	3433	-	K

IGBT Electrical characteristics (T_j=25°C unless otherwise specified, chip)

Symbol	Item	Condition		Value			Unit	
				Min.	Typ.	Max.		
V _{CE(sat)}	Collector-Emitter Saturation Voltage	I _C =600A	V _{GE} =15V	T _j =25°C	-	1.60	1.92	V
				T _j =125°C	-	1.73	-	V
				T _j =150°C	-	1.80	-	V
				T _j =175°C	-	1.85	-	V
V _{GE(th)}	Gate-Emitter threshold Voltage	I _C =23mA, V _{CE} =V _{GE}		5.0	5.8	6.5	V	
Q _G	Gate charge	V _{GE} = -15V to +15V		-	6.9	-	uC	
R _{Gint}	Internal gate resistor	-	T _j =25°C	-	0.53	-	Ω	
C _{ies}	Input Capacitance	V _{CE} =25V,		T _j =25°C	-	86.4	-	nF
C _{oes}	Output Capacitance	V _{GE} =0V			-	2.35	-	nF
C _{res}	Reverse transfer Capacitance	f=1MHz			-	0.66	-	nF
I _{CES}	Collector- Emitter Cut off Current	V _{CE} =1200V, V _{GE} =0V		T _j =25°C	-	-	1	mA
I _{GES}	Gate-Emitter Leakage Current	V _{GE} =20V, V _{CE} =0V		T _j =25°C	-	-	1	uA
t _{d(on)}	Turn-on delay time	V _{CC} =600V I _C =600A V _{GE} =+15V/-8V R _{Gon} = R _{Goff} =2.2Ω Inductive load		T _j =25°C	-	400	-	ns
				T _j =150°C	-	394	-	ns
t _r	Rise time			T _j =25°C	-	68	-	ns
				T _j =150°C	-	84	-	ns
t _{d(off)}	Turn-off delay time			T _j =25°C	-	797	-	ns
				T _j =150°C	-	858	-	ns
t _f	Fall time			T _j =25°C	-	107	-	ns
				T _j =150°C	-	258	-	ns
E _{on}	Turn-on power dissipation			T _j =25°C	-	22.6	-	mJ
				T _j =150°C	-	52.4	-	mJ
E _{off}	Turn-off power dissipation	T _j =25°C	-	77.1	-	mJ		
		T _j =150°C	-	80.0	-	mJ		
R _{th(j-c)}	Thermal Resistance, Junction to Case (IGBT)			-	0.045	-	°C /W	
R _{th(c-s)}	Thermal Resistance, Case to sink (Conductive Grease applied) , Note1			-	0.015	-	°C /W	

Note1: Assumes Thermal Conductivity of grease is 2.8 W/m · K and thickness is 50um.

Freewheeling Diode Electrical characteristics ($T_j=25^\circ\text{C}$ unless otherwise specified, chip)

Symbol	Item	Condition	Value			Unit	
			Min.	Typ.	Max.		
V_F	Diode Forward Voltage	$I_F=600\text{A}, V_{GE}=0\text{V}$	$T_j=25^\circ\text{C}$	-	1.64	1.97	V
			$T_j=125^\circ\text{C}$	-	1.48	-	V
			$T_j=150^\circ\text{C}$	-	1.49	-	V
			$T_j=175^\circ\text{C}$	-	1.44	-	V
t_{rr}	Reverse recovery time	(Switch side) $V_{CC}=600\text{V}, I_C=600\text{A}$	$T_j=25^\circ\text{C}$	-	316	-	ns
			$T_j=150^\circ\text{C}$	-	514	-	ns
I_{RM}	Peak reverse recovery Current	$V_{GE}=+15\text{V}/-8\text{V}, R_G=2.2\Omega$ (FRD side)	$T_j=25^\circ\text{C}$	-	387	-	A
			$T_j=150^\circ\text{C}$	-	555	-	A
Q_{rr}	Recovered charge	$V_{rr}=600\text{V}, I_F=600\text{A}$ $V_{GE}=-8\text{V}$	$T_j=25^\circ\text{C}$	-	46.7	-	μC
			$T_j=150^\circ\text{C}$	-	107.7	-	μC
E_{rr}	Reverse recovered energy	Inductive load switching operation	$T_j=25^\circ\text{C}$	-	23.9	-	mJ
			$T_j=150^\circ\text{C}$	-	47.2	-	mJ
$R_{th(j-c)}$	Thermal Resistance, Junction to Case (Diode)		-	0.063	-	$^\circ\text{C}/\text{W}$	
$R_{th(c-s)}$	Thermal Resistance, Case to sink (Conductive Grease applied), Note1		-	0.020	-	$^\circ\text{C}/\text{W}$	

Note1: Assumes Thermal Conductivity of grease is $2.8 \text{ W/m} \cdot \text{K}$ and thickness is $50\mu\text{m}$.

Test Conditions

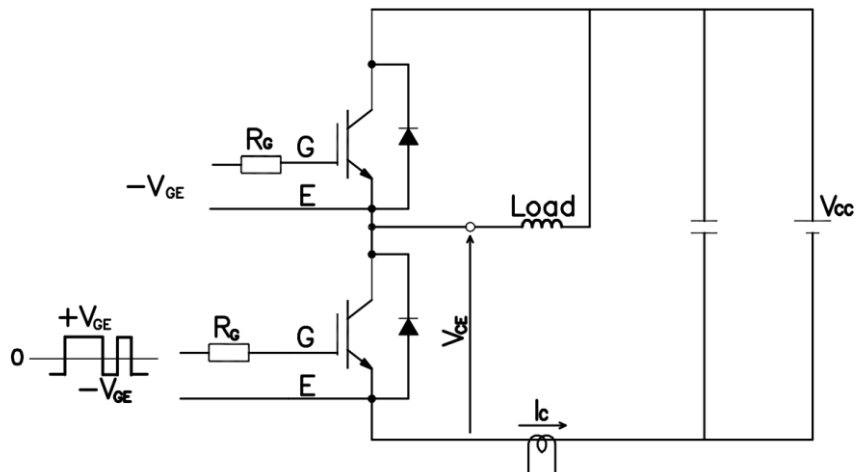

Figure 3. Switching time measure circuit

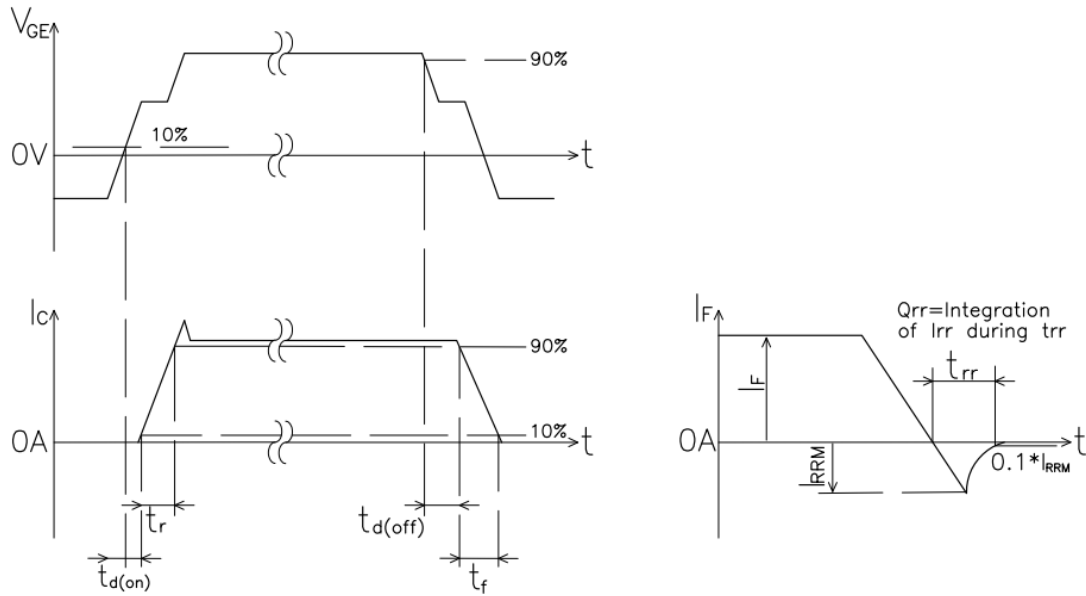
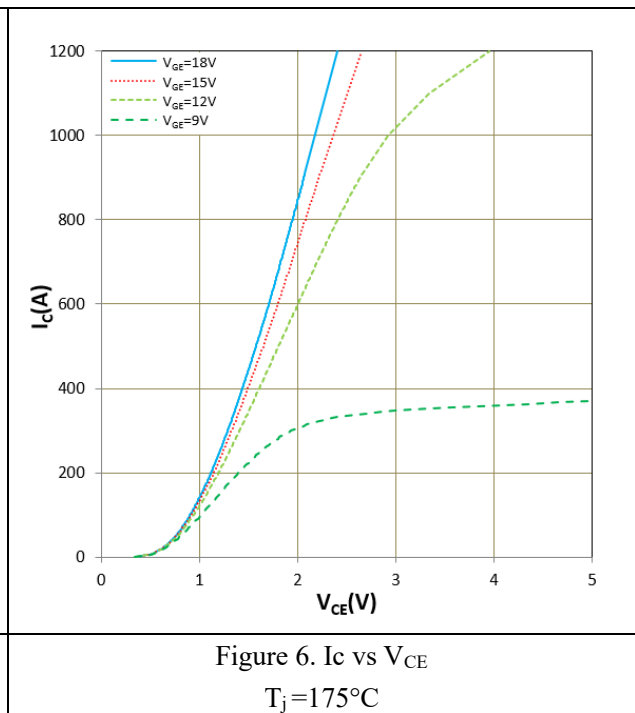
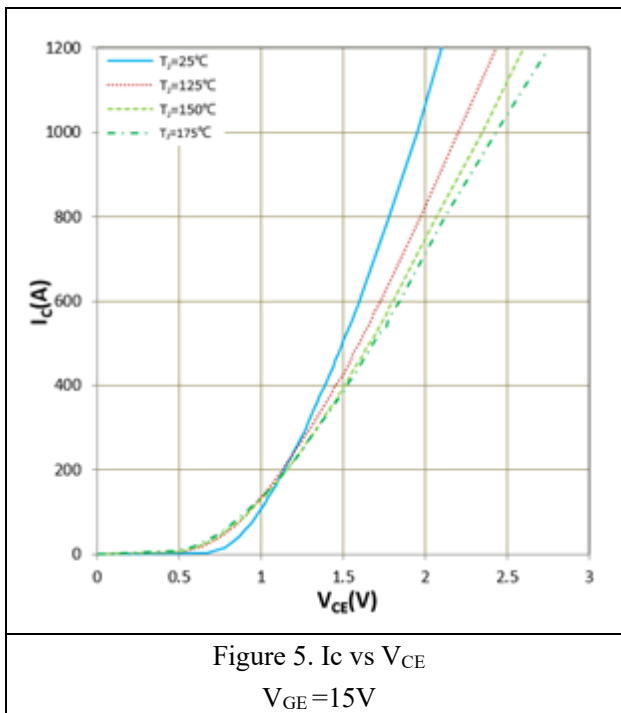

Figure 4. Switching time definition



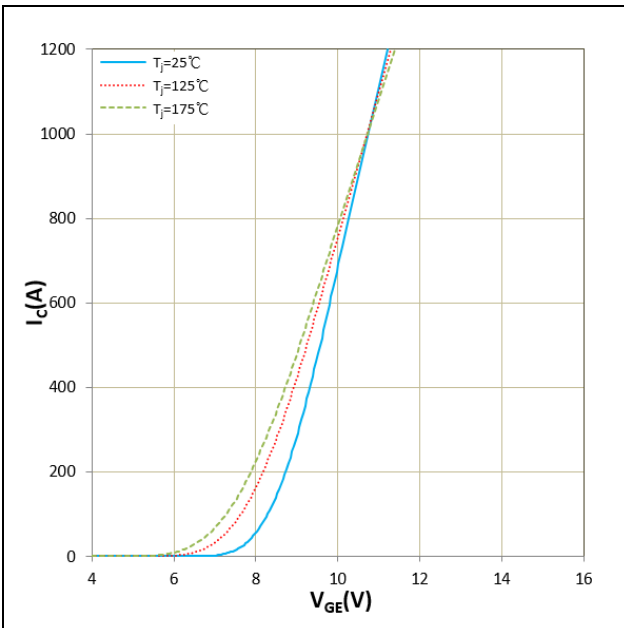

Figure 7. I_c vs V_{GE}
 $V_{CE}=20V$

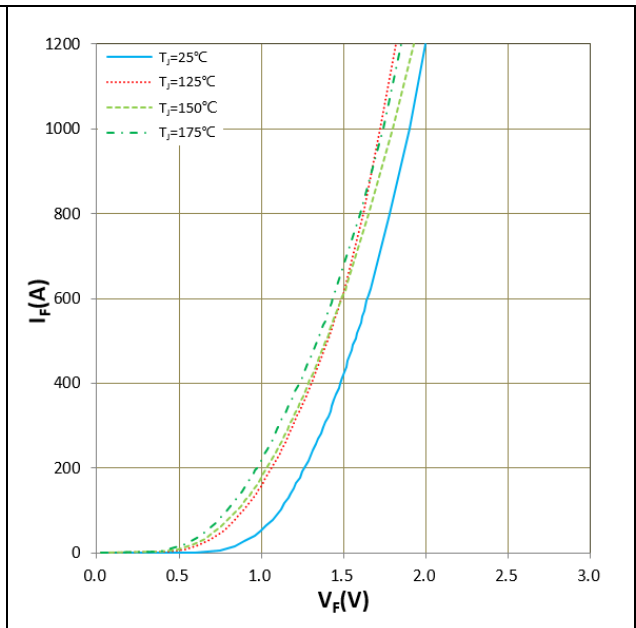

Figure 8. I_F vs V_F

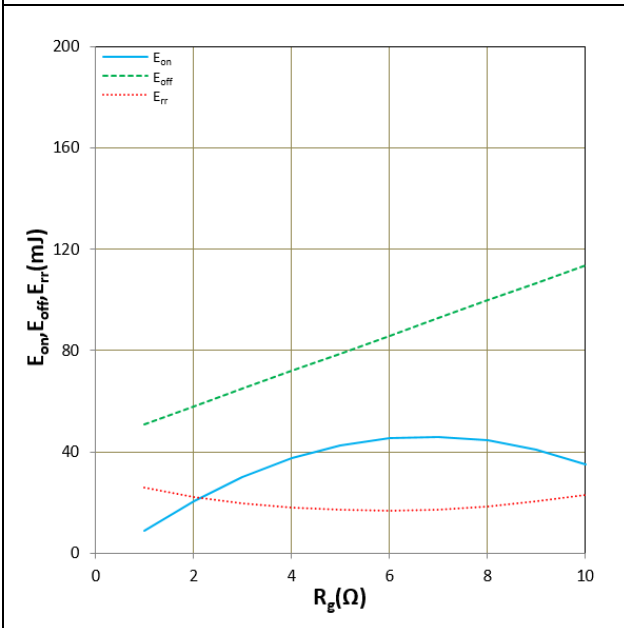

Figure 9. E_{on} , E_{off} , E_{rr} vs R_g (Typ)
 $V_{CC}=600V$, $V_{GE}=+15V/-8V$, $I_c=600A$, $T_j=25^\circ C$
Inductive Load

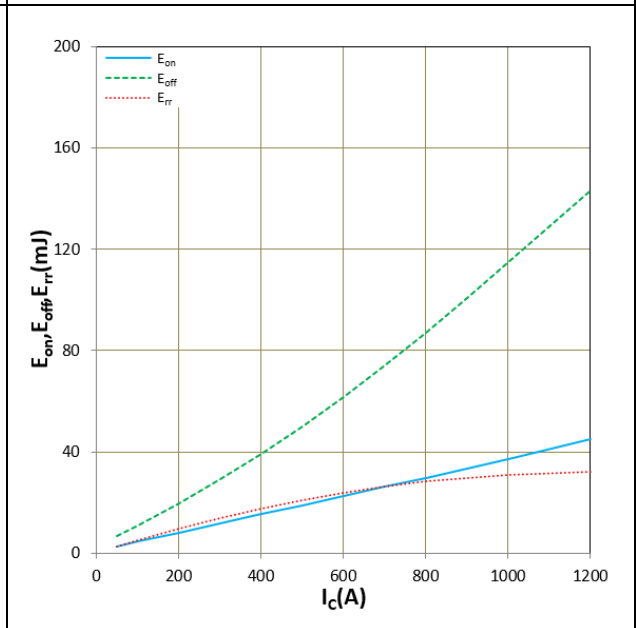

Figure 10. E_{on} , E_{off} , E_{rr} vs I_c (Typ)
 $V_{CC}=600V$, $V_{GE}=+15V/-8V$, $R_g=2.2\Omega$, $T_j=25^\circ C$
Inductive Load

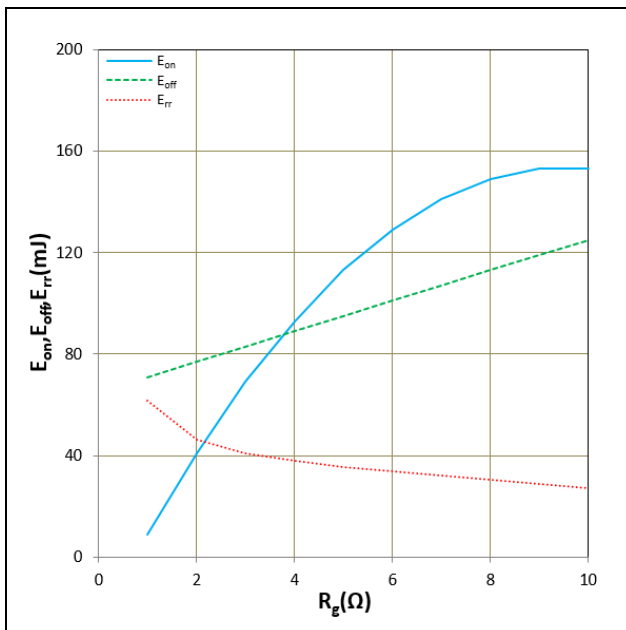

Figure 11. E_{on} , E_{off} , E_{rr} vs R_g (Typ)
 $V_{CC}=600V$, $V_{GE}=+15V/-8V$, $I_C=600A$, $T_j=150^\circ C$
 Inductive Load

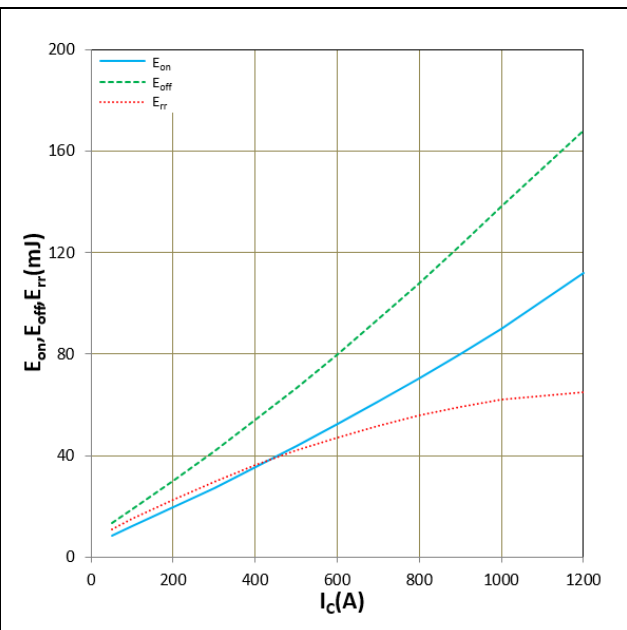

Figure 12. E_{on} , E_{off} , E_{rr} vs I_c (Typ)
 $V_{CC}=600V$, $V_{GE}=+15V/-8V$, $R_g=2.2\Omega$, $T_j=150^\circ C$
 Inductive Load

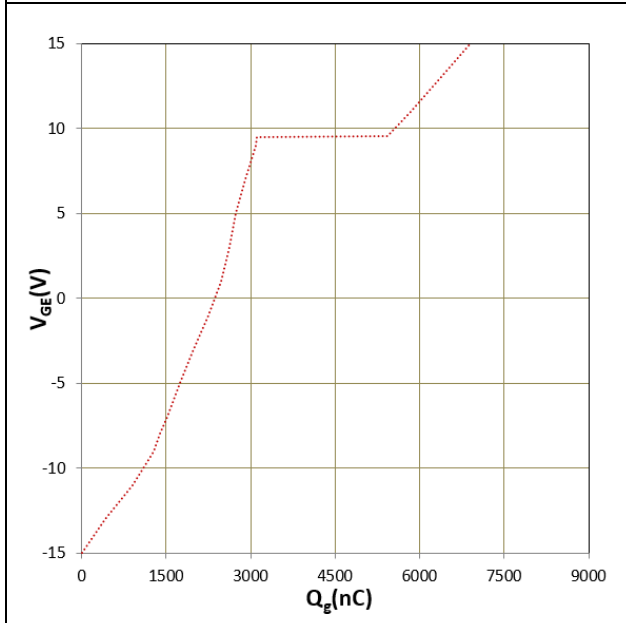

Figure 13. Gate charge

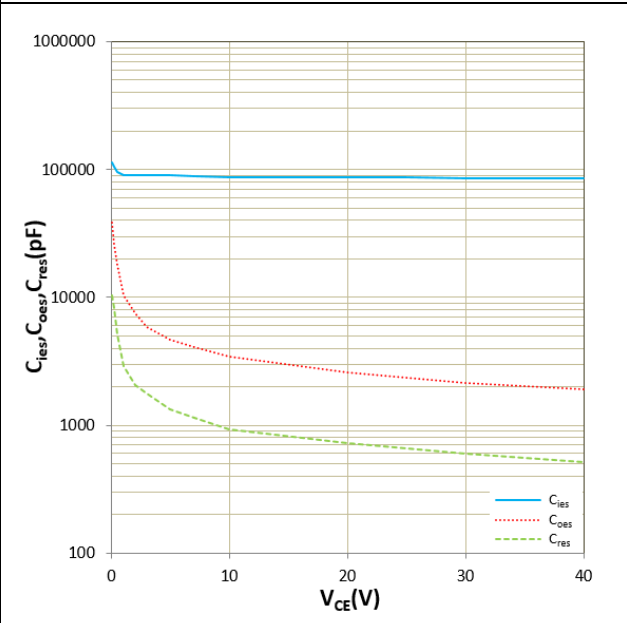

Figure 14. C_{ies} , C_{oes} , C_{res} vs V_{CE}
 $T_j=25^\circ C$, $f=1MHz$

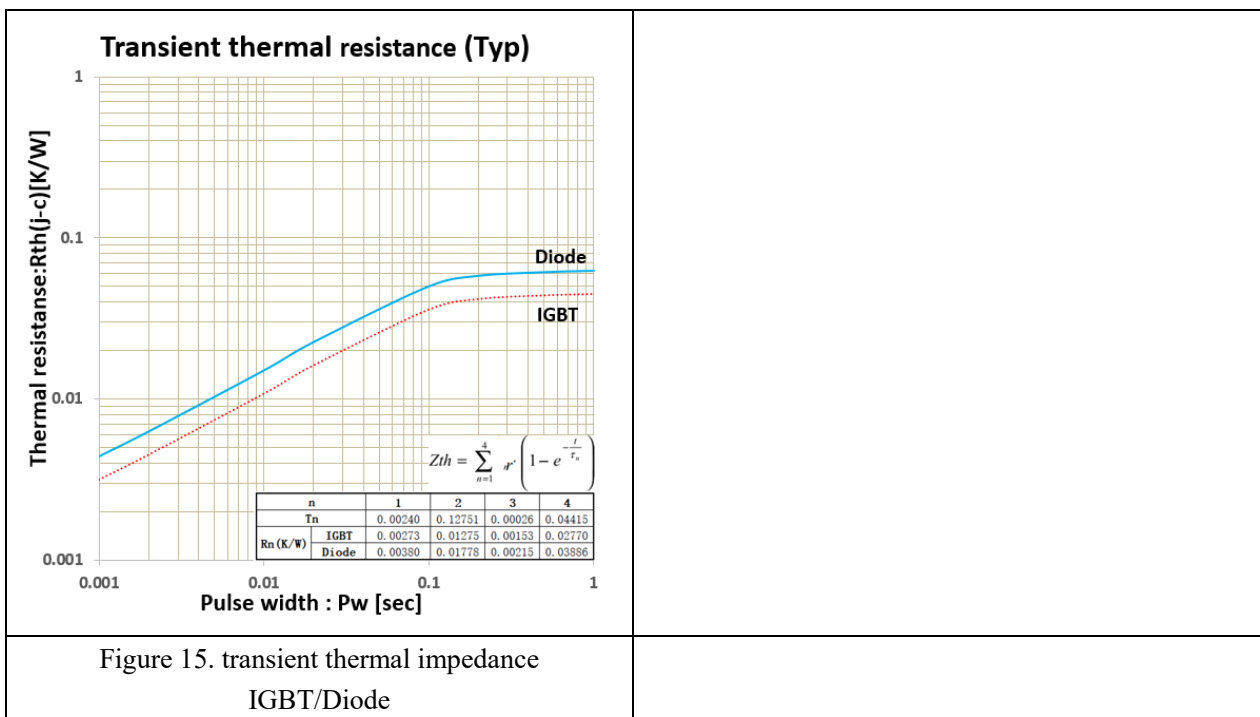

Figure 15. transient thermal impedance
IGBT/Diode

IMPORTANT NOTICE:

This product data sheet describes the characteristics of this product for which a warranty is granted. Any such warranty is granted exclusively under the terms and conditions of the supply agreement. There will be no guarantee or of any kind for the product and its characteristics.

The data contained in this document is exclusively intended for technically trained staff. You and your technical departments will have to evaluate the product's suitability for the intended application and the completeness of the product data concerning such application.

Due to technical requirements, our product may contain dangerous substances. For information on the types in question, please contact the sales staff responsible for you.

Changes to this product data sheet are reserved.

Please contact the sales staff (Sales@leapers-power.com) for further information on the product, technology, delivery terms, conditions and prices.