

Description

The DFH900HF12I4ME7 is a Half Bridge SiC Hybrid Power Module. It integrates high performance IGBT chips and SiC SBD designed for the applications such as High Power Switching Application and Motor control.



Features

- Blocking voltage:1200V
- Low saturation voltage $V_{CE(sat)}$
- Low Switching Losses
- Low Thermal Resistance
- Thermistor inside

Applications

- High Power Switching Applications
- Motor Drives
- Solar inverter Systems
- Uninterrupted Power Supply

Circuit diagram

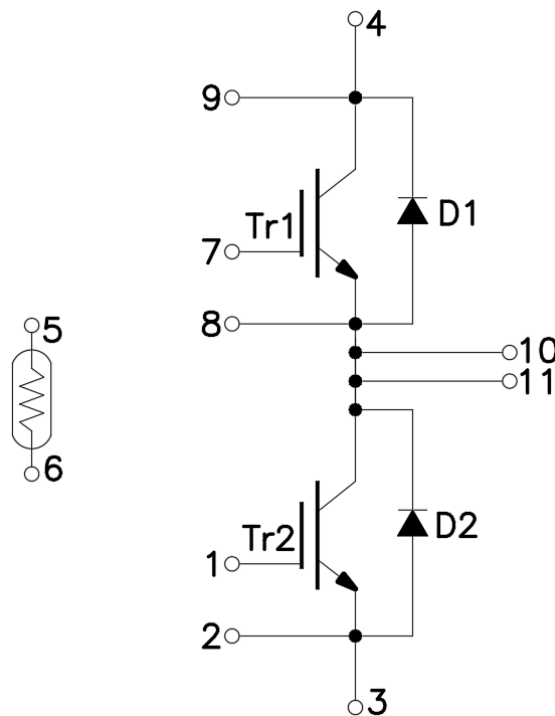

Figure 1. Out drawing & circuit diagram for DFH900HF12I4ME7

Module

Parameter	Condition	Value	Unit
Isolation Voltage	RMS, f = 50Hz, t = 1 min	3.4	kV
Material of module baseplate	-	Cu	-
Creepage distance	terminal to heatsink terminal to terminal	14.5 13	mm
Clearance	terminal to heatsink terminal to terminal	12.5 10	mm
CTI	-	>400	-
Module lead resistance, terminals – chip	T _C = 25°C	0.8	mΩ
Mounting torque for module mounting	M5, M6	3 to 6	Nm
Weight	-	350	g

Maximum Ratings (T_j = 25°C unless otherwise specified)

Symbol	Parameter	Condition	Ratings	Unit
V _{CES}	Collector-Emitter Voltage	G-E Short	1200	V
V _{GES}	Gate-Emitter Voltage	C-E Short	±20	V
I _C	DC Continuous Collector Current	T _C = 75°C, T _j = 150°C	900	A
I _{CM}	Pulse Collector Current	t _p = 1ms, Note1	1800	A
P _C	Maximum Power Dissipation	T _C = 25°C, T _j = 150°C (IGBT)	3125	W
I _F	Diode Forward Current	-	900	A
I _{FRM}	Repetitive peak forward Current	t _p = 1ms, Note1	1800	A
T _{vjop}	Operating junction temperature	Note2	-40 to 175	°C
T _{stg}	Storage temperature	-	-40 to 125	°C

Note1: Pulse width limited by maximum junction temperature

Note2: T_{vjop} > 150°C is only allowed for operation at overload conditions

NTC characteristics

Symbol	Parameter	Condition	Value			Unit
			Min.	Typ.	Max.	
R ₂₅	Resistance	T _C = 25°C	-	5	-	kΩ
ΔR/R	Deviation of R ₁₀₀	T _C = 100°C, R ₁₀₀ = 493Ω	-5	-	5	%
P ₂₅	Power dissipation	T _C = 25°C	-	-	20	mW
B _{25/50}	B-value	R ₂ = R ₂₅ exp [B _{25/50} (1/T ₂ - 1/(298,15 K))]	-	3375	-	K
B _{25/80}	B-value	R ₂ = R ₂₅ exp [B _{25/80} (1/T ₂ - 1/(298,15 K))]	-	3411	-	K
B _{25/100}	B-value	R ₂ = R ₂₅ exp [B _{25/100} (1/T ₂ - 1/(298,15 K))]	-	3433	-	K

IGBT Electrical characteristics (T_j=25°C unless otherwise specified, chip)

Symbol	Item	Condition		Value			Unit	
				Min.	Typ.	Max.		
V _{CE(sat)} (Chip)	Collector-Emitter Saturation Voltage	I _C =900A V _{GE} =15V	T _j =25°C	-	1.72	2.06	V	
			T _j =125°C	-	2.00	-		
			T _j =150°C	-	2.10	-		
			T _j =175°C	-	2.18	-		
V _{GE(th)}	Gate-Emitter threshold Voltage	I _C =25mA, V _{CE} =V _{GE}		5.0	-	6.5	V	
Q _G	Gate charge	V _{GE} = -15V to +15V		-	7.6	-	uC	
R _{Gint}	Internal gate resistor	-	T _j =25°C	-	0.5	-	Ω	
C _{ies}	Input Capacitance	V _{CE} =25V, V _{GE} =0V f=1MHz	T _j =25°C	-	133.8	-	nF	
C _{oes}	Output Capacitance			-	4.35	-	nF	
C _{res}	Reverse transfer Capacitance			-	1.18	-	nF	
I _{CES}	Collector- Emitter Cut off Current	V _{CE} =1200V, V _{GE} =0V		T _j =25°C	-	-	1	mA
I _{GES}	Gate-Emitter Leakage Current	V _{GE} = 20V, V _{CE} =0V		T _j =25°C	-	-	1.5	uA
t _{d(on)}	Turn-on delay time	V _{CC} =600V I _C = 900A V _{GE} =+15V/-8V R _g =2.0Ω Inductive load	T _j =25°C	-	412	-	ns	
			T _j =150°C	-	423	-		
t _r	Rise time		T _j =25°C	-	112	-	ns	
			T _j =150°C	-	126	-		
t _{d(off)}	Turn-off delay time		T _j =25°C	-	638	-	ns	
			T _j =150°C	-	820	-		
t _f	Fall time		T _j =25°C	-	142	-	ns	
			T _j =150°C	-	146	-		
E _{on}	Turn-on power dissipation		T _j =25°C	-	46.1	-	mJ	
			T _j =150°C	-	65.4	-		
E _{off}	Turn-off power dissipation		T _j =25°C	-	95.1	-	mJ	
			T _j =150°C	-	104.6	-		
R _{th(j-c)}	Thermal Resistance, Junction to Case (IGBT)		-	0.040	-	K/W		
R _{th(c-s)}	Thermal Resistance, Case to sink (Conductive Grease applied), Note1		-	0.015	-	K/W		

Note1: Assumes Thermal Conductivity of grease is 2.8W/m·K and thickness is 50um.

SiC SBD Electrical characteristics (T_j=25°C unless otherwise specified, chip)

Symbol	Item	Condition	Value			Unit	
			Min.	Typ.	Max.		
V _F	Diode Forward Voltage	I _F =900A V _{GE} =0V	T _j =25°C	-	1.85	-	V
			T _j =125°C	-	2.60	-	
			T _j =150°C	-	2.90	-	
			T _j =175°C	-	3.10	-	
T _{rr}	Reverse recovery time	V _{CC} =600V	T _j =25°C	-	36	-	ns
			T _j =150°C	-	33	-	
I _{RM}	Peak reverse recovery Current	I _C =900A V _{GE} =+15/-8V	T _j =25°C	-	110	-	A
			T _j =150°C	-	73	-	
Q _{rr}	Reverse recovery charge	R _g =2.0Ω Inductive load switching operation	T _j =25°C	-	2.51	-	uC
			T _j =150°C	-	1.44	-	
E _{rr}	Reverse recovered energy	switching operation	T _j =25°C	-	0.62	-	mJ
			T _j =150°C	-	0.27	-	
R _{th(j-c)}	Thermal Resistance, Junction to Case (Diode)		-	0.070	-	K/W	
R _{th(c-s)}	Thermal Resistance, Case to sink (Conductive Grease applied) , Note1		-	0.025	-	K/W	

Note1: Assumes Thermal Conductivity of grease is 2.8W/m·K and thickness is 50um.

Test Conditions

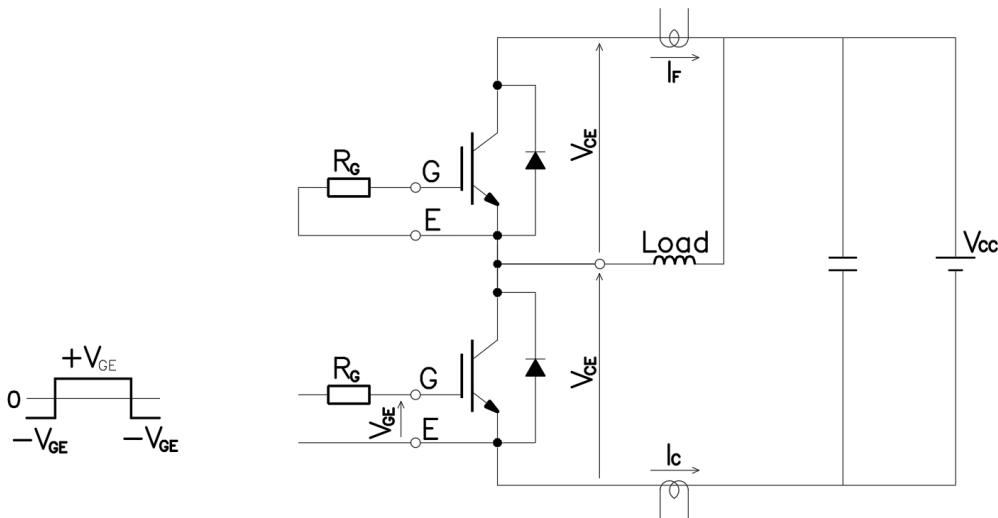

Figure 3. Switching time measure circuit

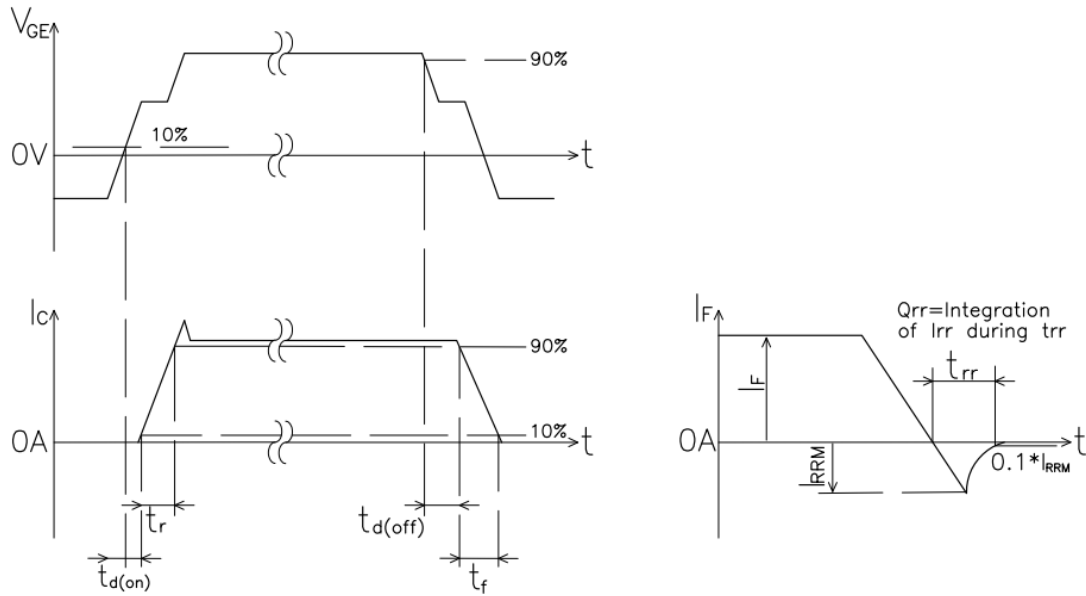
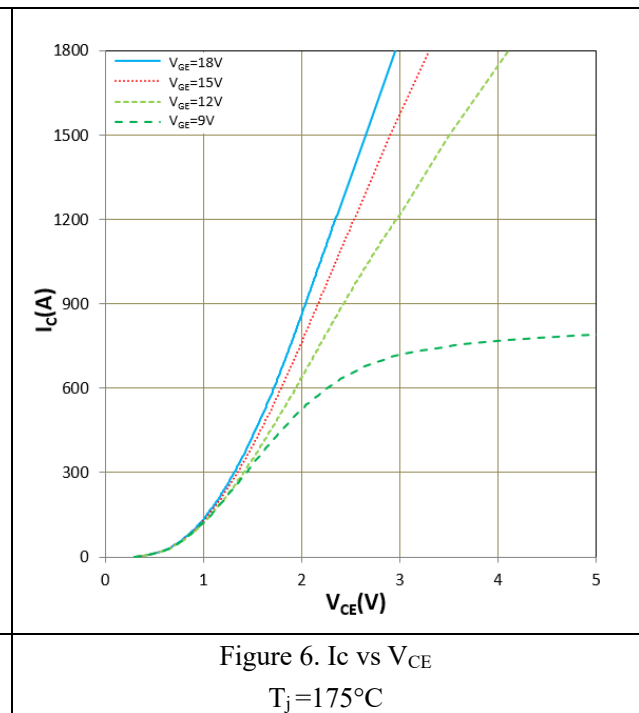
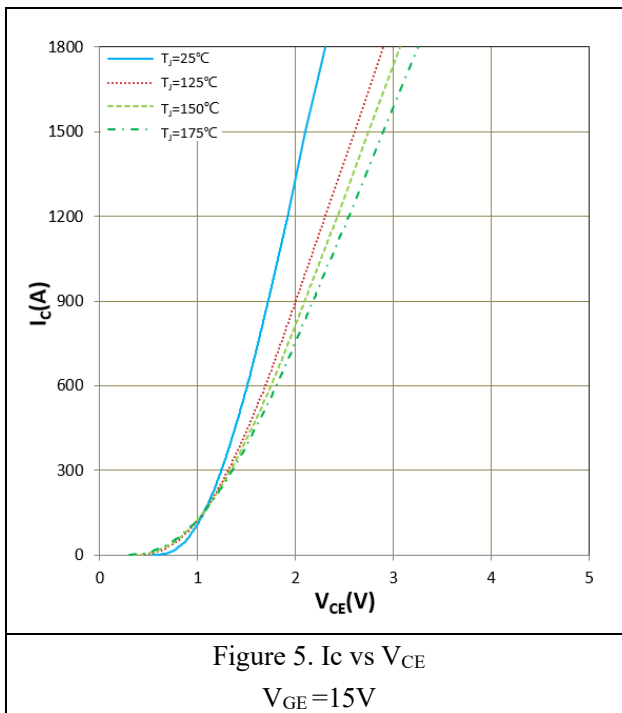

Figure 4. Switching time definition



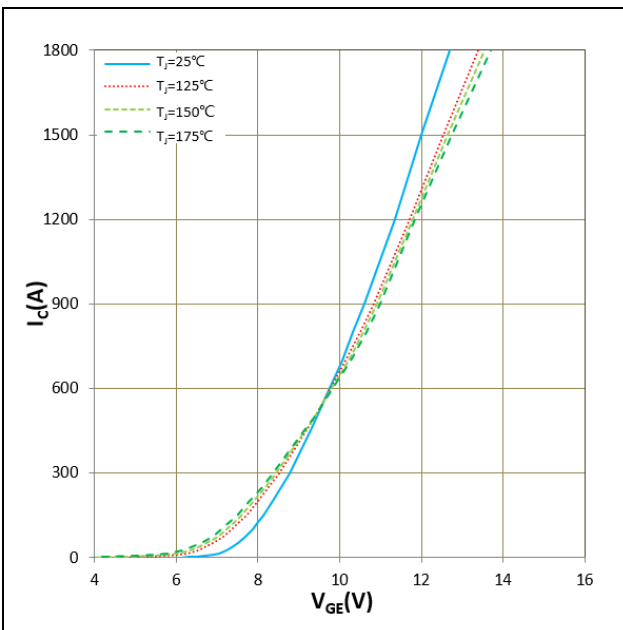

Figure 7. I_c vs V_{GE}
 $V_{CE}=20V$

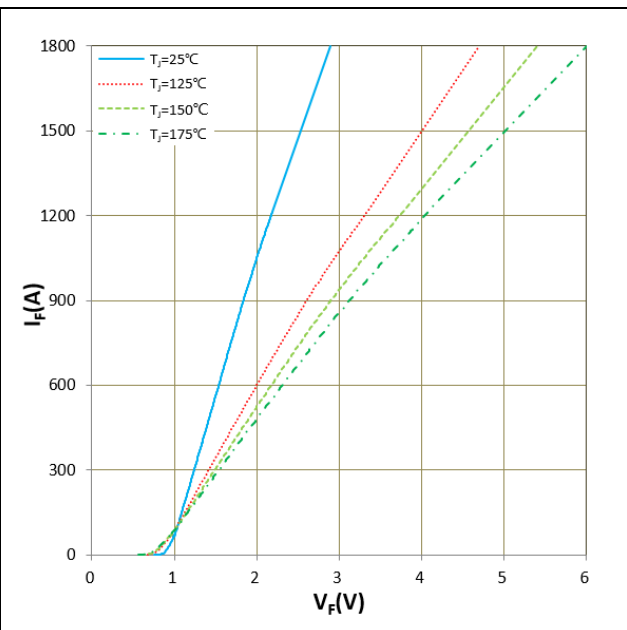

Figure 8. I_F vs V_F

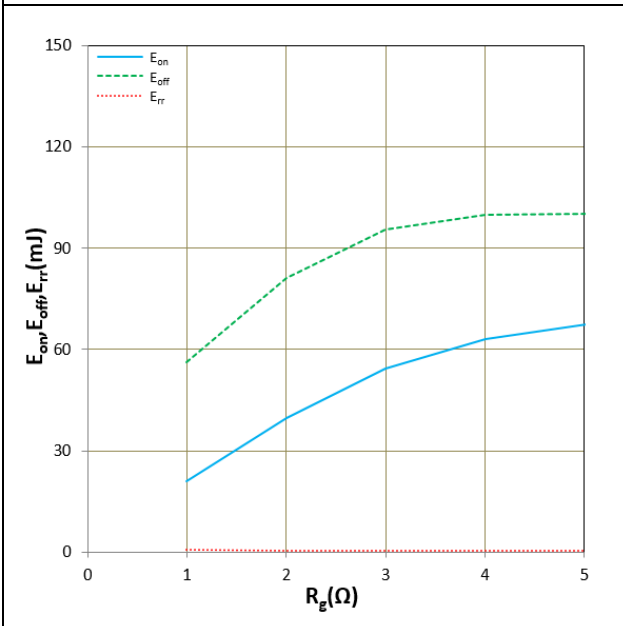

Figure 9. E_{on} , E_{off} , E_{tr} vs R_g (Typ)
 $V_{CC}=600V$, $V_{GE}=+15V/-8V$, $I_c=900A$, $T_j=25^\circ C$
Inductive Load

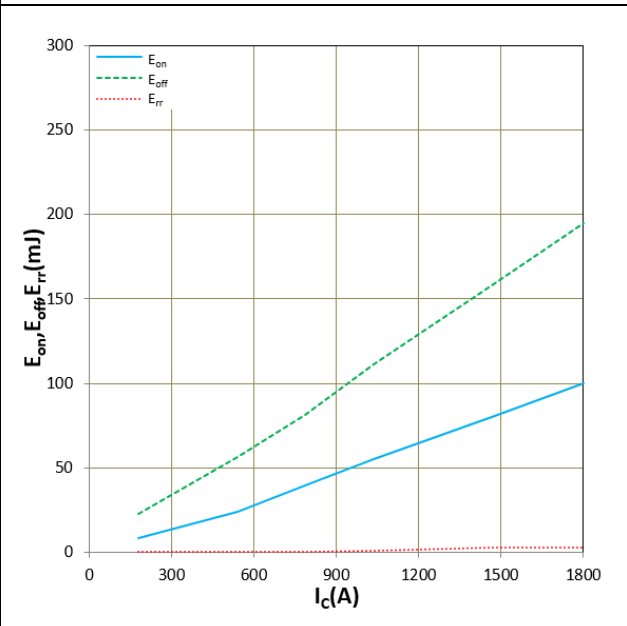

Figure 10. E_{on} , E_{off} , E_{tr} vs I_c (Typ)
 $V_{CC}=600V$, $V_{GE}=+15V/-8V$, $R_g=2.0\Omega$, $T_j=25^\circ C$
Inductive Load

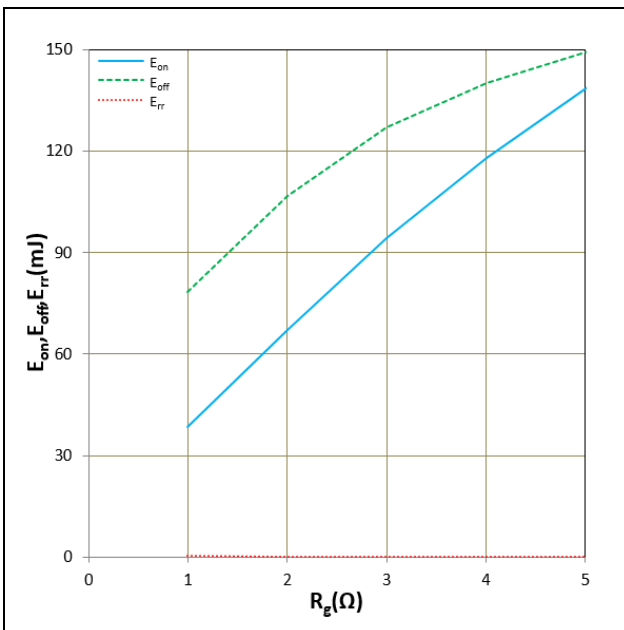

Figure 11. E_{on} , E_{off} , E_{rr} vs R_g (Typ)
 $V_{CC}=600V$, $V_{GE}=+15V/-8V$, $I_C=900A$, $T_j=150^\circ C$
 Inductive Load

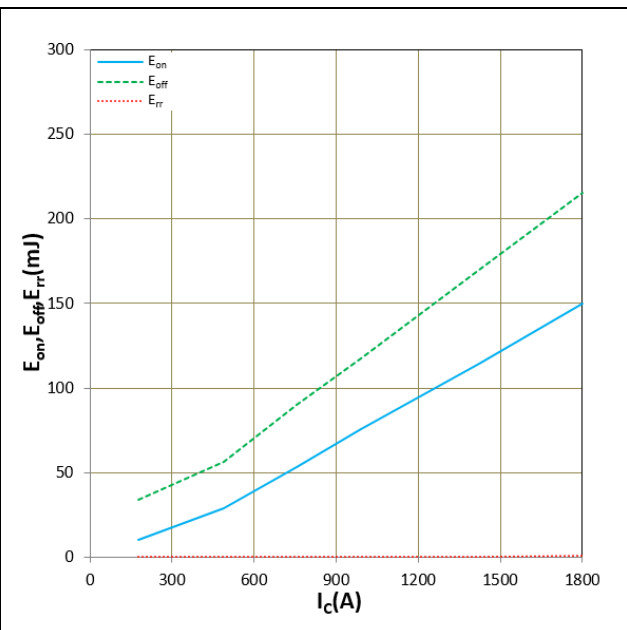

Figure 12. E_{on} , E_{off} , E_{rr} vs I_c (Typ)
 $V_{CC}=600V$, $V_{GE}=+15V/-8V$, $R_g=2.0\Omega$, $T_j=150^\circ C$
 Inductive Load

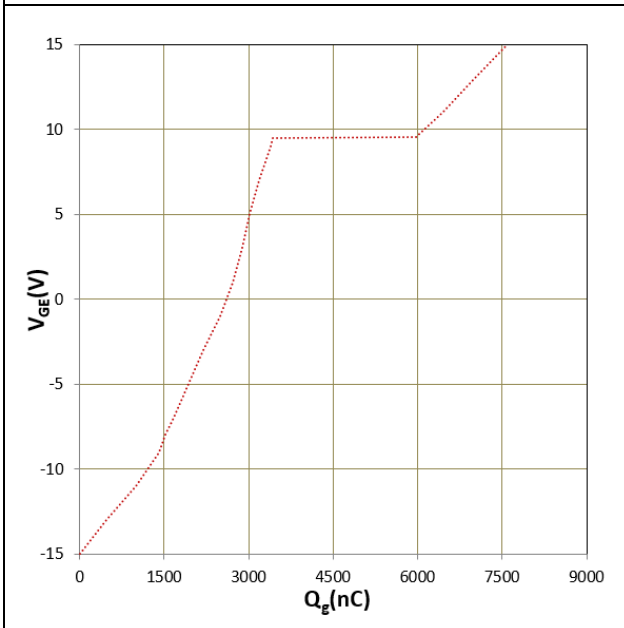

Figure 13. Gate charge
 $V_{CC}=600V$, $I_C=900A$, $T_j=25^\circ C$

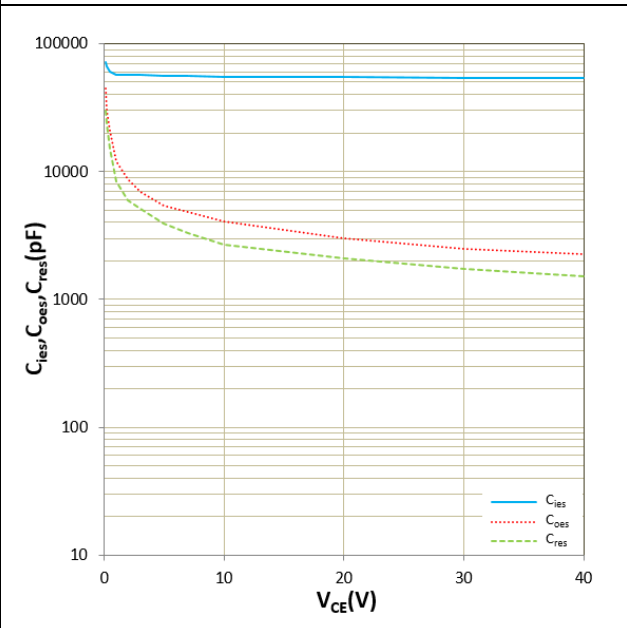
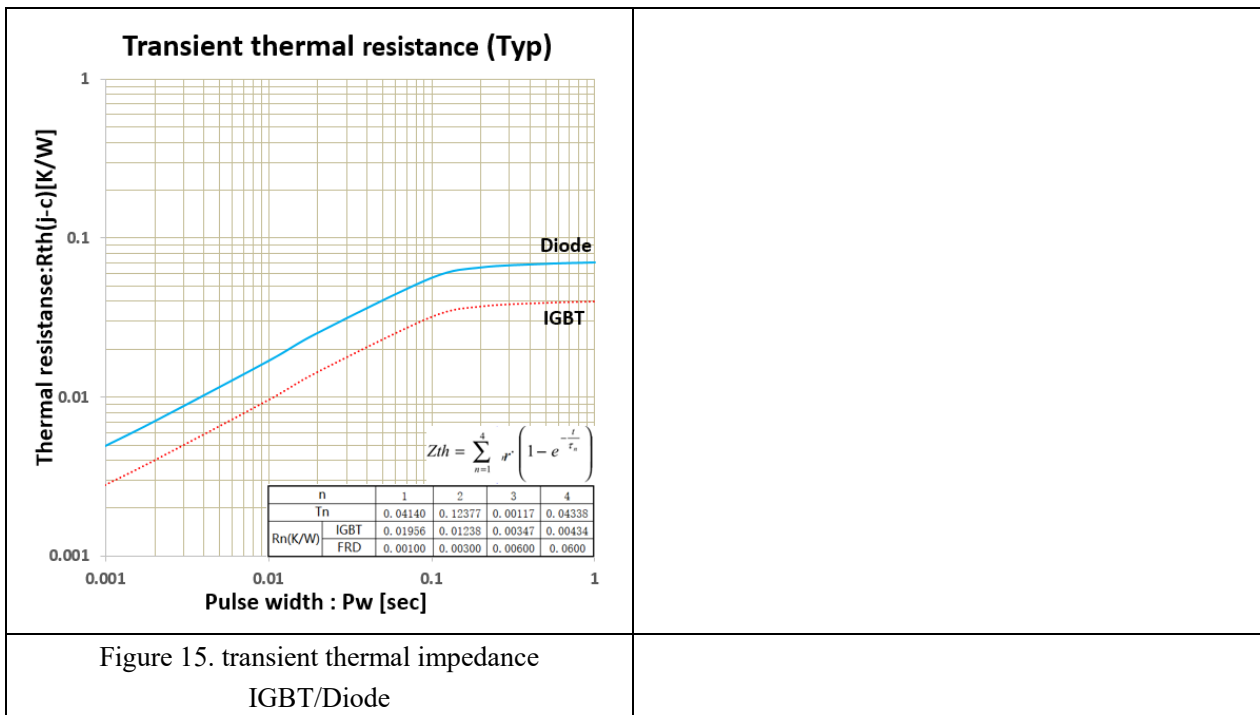

Figure 14. C_{ies} , C_{oes} , C_{res} vs V_{CE}
 $T_j=25^\circ C$, $f=1MHz$



IMPORTANT NOTICE:

This product data sheet describes the characteristics of this product for which a warranty is granted. Any such warranty is granted exclusively under the terms and conditions of the supply agreement. There will be no guarantee or of any kind for the product and its characteristics.

The data contained in this document is exclusively intended for technically trained staff. You and your technical departments will have to evaluate the product's suitability for the intended application and the completeness of the product data concerning such application.

Due to technical requirements, our product may contain dangerous substances. For information on the types in question, please contact the sales staff responsible for you.

Changes to this product data sheet are reserved.

Please contact the sales staff (Sales@leapers-power.com) for further information on the product, technology, delivery terms, conditions and prices.