

## Description

The DFD450HF17I3A1 is a Half Bridge SiC Schottky Diode Power Module. It integrates high performance SiC Schottky Diode chips designed for the applications such as Rectifier Application and Battery chargers.



## Features

- SiC Schottky Diode
- $V_{DC}$ : 1700V
- 175°C maximum junction temperature
- Low thermal resistance with Si<sub>3</sub>N<sub>4</sub> AMB
- Fast, temperature-independent switching
- Reduced temperature dependence of  $V_F$

## Applications

- Rectifier
- Battery chargers

## Circuit diagram

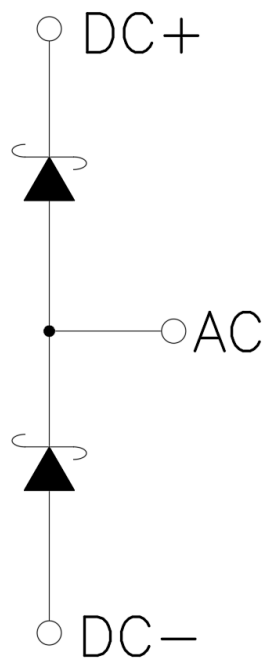

Figure 1. Out drawing & circuit diagram for DFD450HF17I3A1

### Module

Parameter	Condition	Value	Unit
Isolation Voltage	RMS, f =50Hz, t =1min	4.0	kV
Material of module baseplate	-	Cu	-
Creepage distance	terminal to heatsink terminal to terminal	14.5 10	mm
Clearance	terminal to heatsink terminal to terminal	12.5 10	mm
CTI	-	>400	-
Module lead resistance, terminals – chip	T <sub>C</sub> =25°C	0.3	mΩ
Mounting torque for module mounting	M5, M6	3 to 6	Nm
Weight	-	250	g

### Maximum Ratings (T<sub>j</sub>=25°C unless otherwise specified)

Symbol	Parameter	Condition	Ratings	Unit
V <sub>RRM</sub>	Repetitive peak reverse Voltage	T <sub>j</sub> =25°C	1700	V
V <sub>RSM</sub>	Repetitive peak Surge Voltage	T <sub>j</sub> =25°C	1700	V
I <sub>F</sub>	Forward Current	T <sub>F</sub> =60°C	450	A
I <sub>FSM</sub>	Pulse Forward Current	Less than 1ms, Note1	900	A
T <sub>j</sub>	junction temperature	-	-40 to 175	°C
T <sub>stg</sub>	Storage temperature	-	-40 to 125	°C

Note1: Pulse width limited by maximum junction temperature

### Electrical characteristics (T<sub>j</sub>=25°C unless otherwise specified, chip)

Symbol	Item	Condition	Value			Unit	
			Min.	Typ.	Max		
V <sub>DC</sub>	DC blocking Voltage	T <sub>j</sub> =25°C	1700	-	-	V	
V <sub>F</sub>	Diode forward Voltage	I <sub>F</sub> =450A	T <sub>j</sub> =25°C	-	1.80	2.2	V
			T <sub>j</sub> =125°C	-	2.70	-	
			T <sub>j</sub> =175°C	-	3.45	-	
I <sub>R</sub>	Reverse Current	V <sub>R</sub> =1700V	T <sub>j</sub> =25°C	-	28	2100	μA
			T <sub>j</sub> =125°C	-	168	-	
			T <sub>j</sub> =175°C	-	700	-	
Q <sub>C</sub>	Total capacitive charge	V <sub>R</sub> =1700V	T <sub>j</sub> =25°C	-	2828	-	nC
C	Total capacitance	V <sub>R</sub> =1700V	f =1MHz	-	1200	-	pF
R <sub>th(j-c)</sub>	SiC SBD Thermal Resistance	Junction to Case		-	0.06	-	K/W
R <sub>th(c-f)</sub>	Contact thermal Resistance	With thermal conductive grease, Note1		-	0.02	-	K/W

Note1: Assumes Thermal Conductivity of grease is 2.8W/m · K and thickness is 50um.

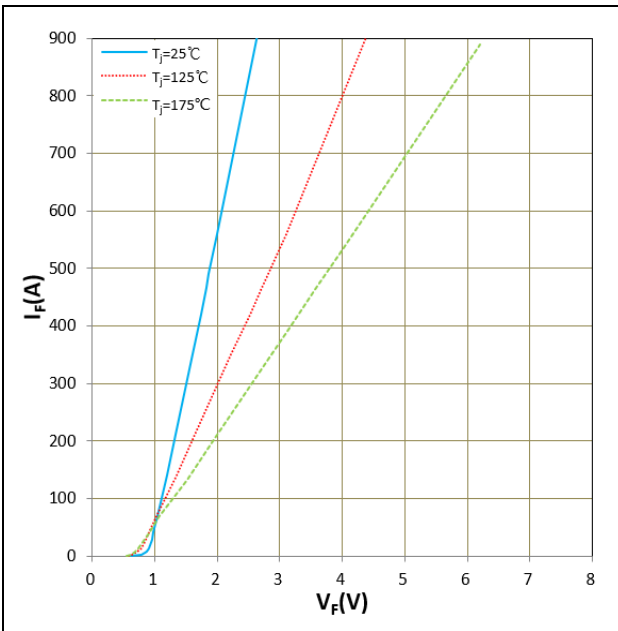

Figure 2.  $I_F$  vs  $V_F$

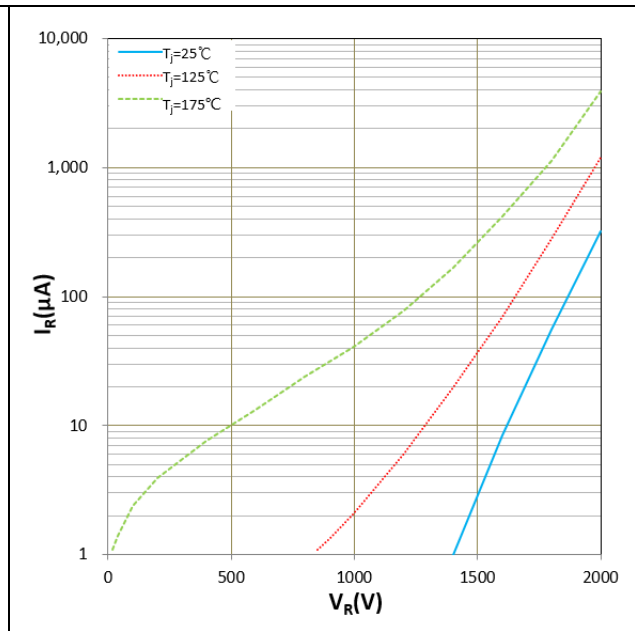

Figure 3.  $I_R$  vs  $V_R$

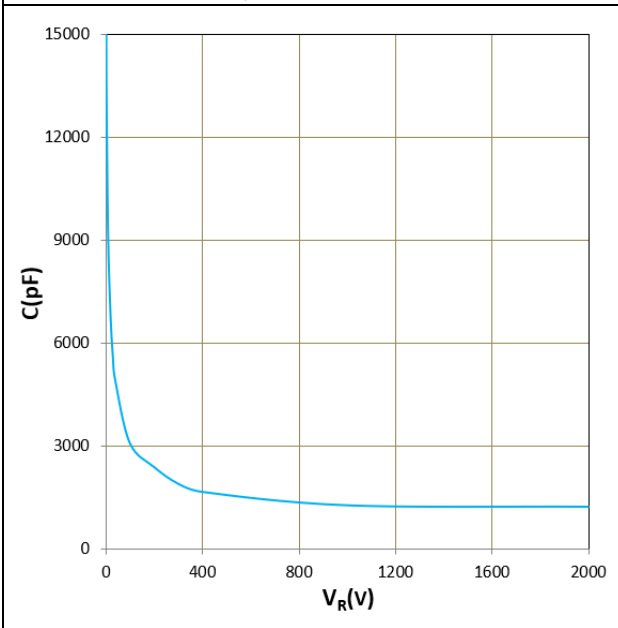

Figure 4.  $C$  vs  $V_R$   
 $T_j = 25^\circ\text{C}$

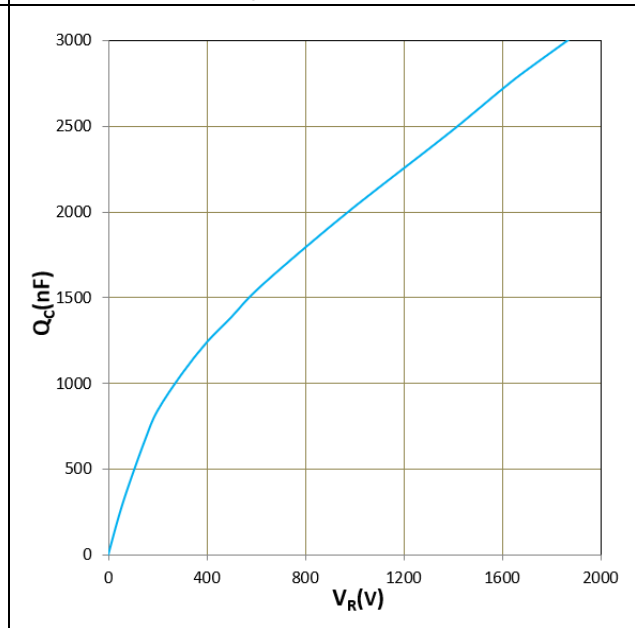
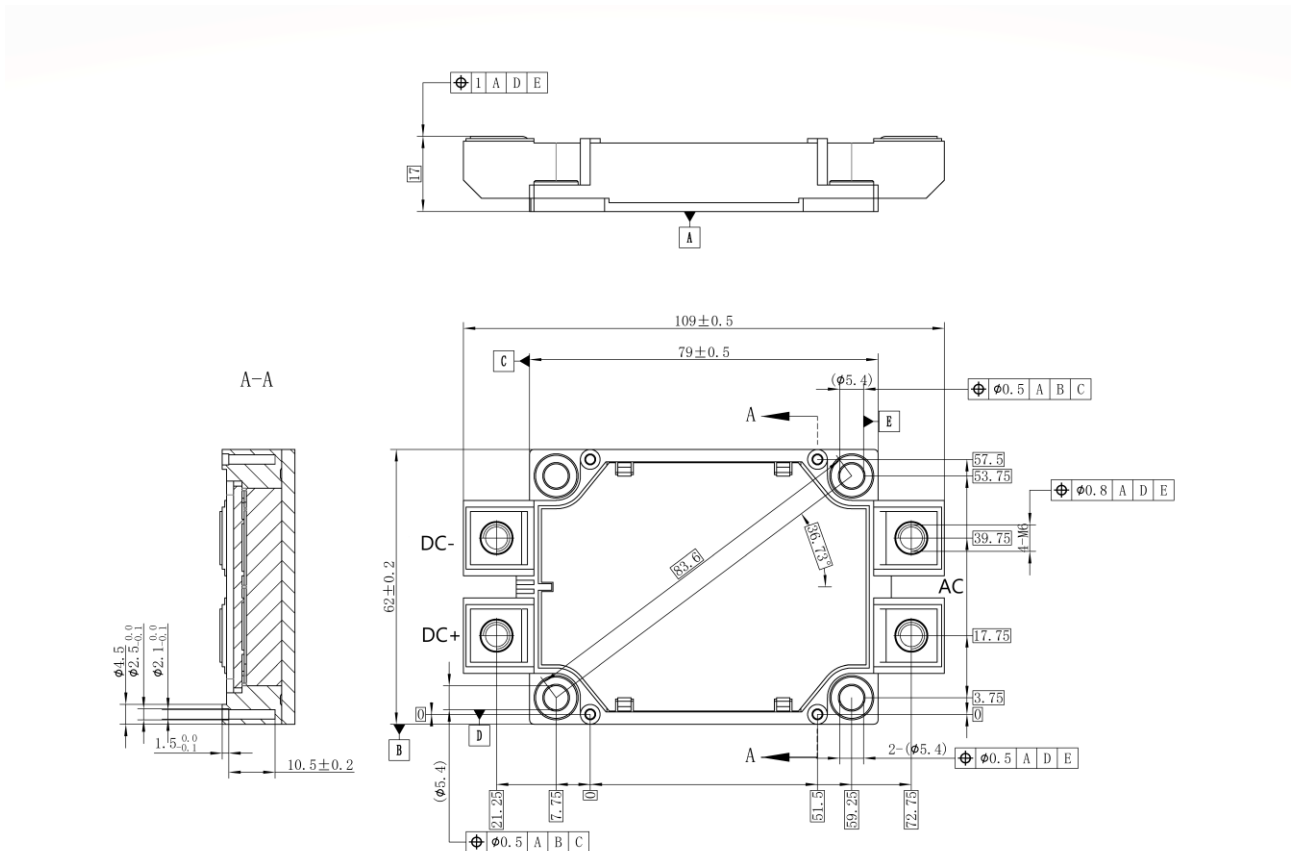

Figure 5.  $Q_C$  vs  $V_R$   
 $T_j = 25^\circ\text{C}$

## Package dimensions



## IMPORTANT NOTICE

This product data sheet describes the characteristics of this product for which a warranty is granted. Any such warranty is granted exclusively under the terms and conditions of the supply agreement. There will be no guarantee or of any kind for the product and its characteristics.

The data contained in this document is exclusively intended for technically trained staff. You and your technical departments will have to evaluate the product's suitability for the intended application and the completeness of the product data concerning such application.

Due to technical requirements, our product may contain dangerous substances. For information on the types in question, please contact the sales staff responsible for you.

Changes to this product data sheet are reserved.

Please contact the sales staff ([Sales@leapers-power.com](mailto:Sales@leapers-power.com)) for further information on the product, technology, delivery terms, conditions and prices.